

# HANOMAG.MF-DOZERS

Cutting Edges



**T O U G H**  
**C O M P O N E N T S**

**TYPE 1**

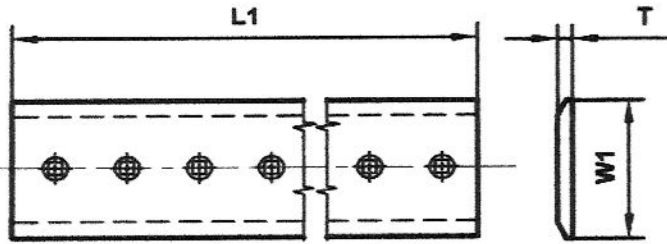

**TYPE 2**

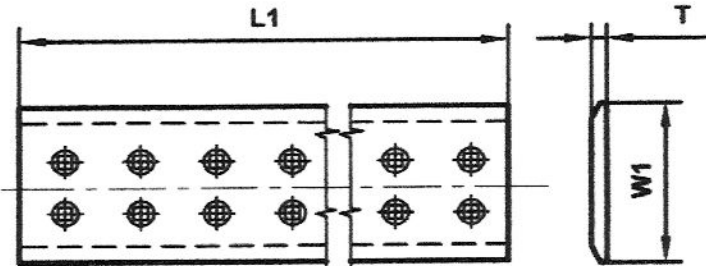

**TYPE 3**

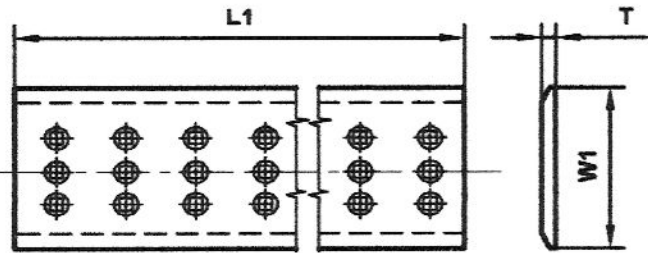

**TYPE 4**

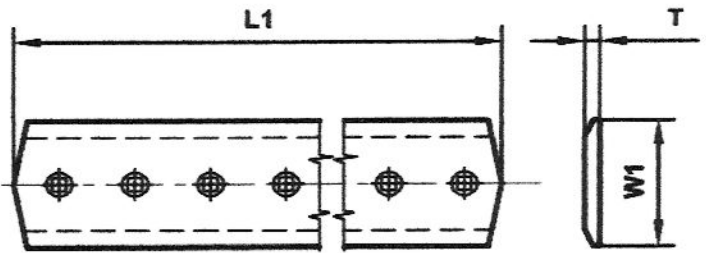

Our parts are not original but they are interchangeable with them. The O.E.M. Part Numbers are give for reference purposes only.

# HANOMAG.MF-DOZERS

End-Bits



**T O U G H**  
**C O M P O N E N T S**

**TYPE 1**  
(Finish Dozing)

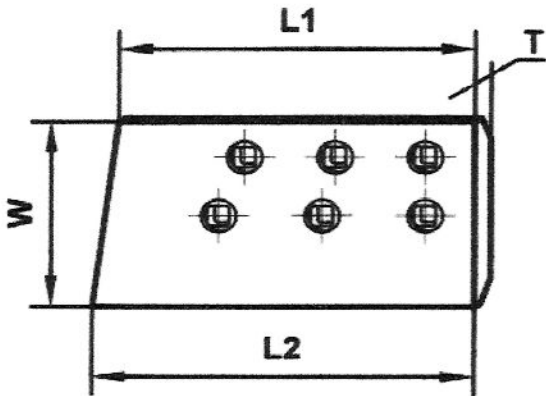

**TYPE 3**  
(General Duty)

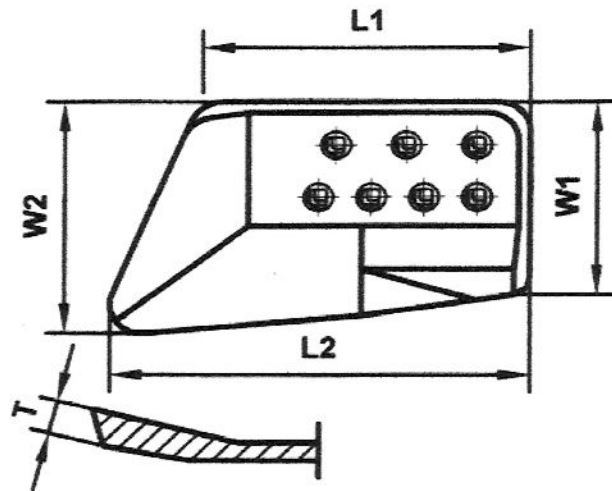

**TYPE 4**  
(Hot Cupped)

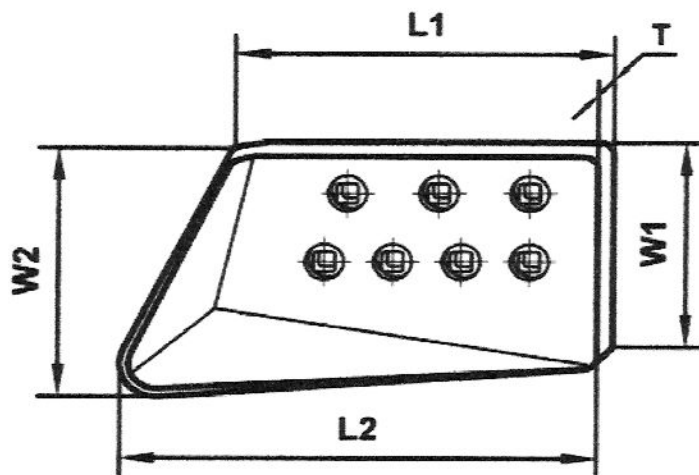

# HANOMAG.MF-DOZERS

Cutting Edges and End Bits



**T O U G H  
C O M P O N E N T S**

Tractor Type	Blade Model	O.E.M. Part Number			MTM Number	Ref.	Description	No Pcs	Millimeters					QI ty.	Nr. H.	Bolt Ø	W. Kg.	
		MILLER	HANOMAG	M. F.					W1	W2	L1	L2	T					
H3				1087387 M1			C.E. BULL STD CTR	1									0	
H4				1087388 M1			E.B. BULL STD AMBI	2									0	
200 2244	ANGLE			1028817 M1			C.E. BULL STD CTR	1									0	
				1028818 M1			E.B. BULL STD RH	1									0	
				1028819 M1			E.B. BULL STD LH	1									0	
MF200 MF200B				1451440 M1			C.E. BULL STD CTR	1									0	
				974153 M1			E.B. BULL STD RH	1									0	
				974152 M1			E.B. BULL STD LH	1									0	
	ANGLE			1451440 M1			C.E. BULL STD CTR	1									0	
				974237 M1			E.B. BULL STD RH	1									0	
				974236 M1			E.B. BULL STD LH	1									0	
MF300	STRAIGH			2708014 M1			C.E. BULL STD CTR	1									0	
				1434127 M2			E.B. BULL STD RH	1									0	
				1434128 M2			E.B. BULL STD LH	1									0	
	ANGLE			2708019 M1			C.E. BULL STD CTR	1										0
				1434127 M2			E.B. BULL STD RH	1										0
				1434128 M2			E.B. BULL STD LH	1										0
				1450790 M1			C.E. BULL STD CTR	1										0
				1435321 M1			E.B. BULL STD RH	1										0
				1435320 M1			E.B. BULL STD LH	1										0
	MF300 MF400				2708011 M1			C.E. BULL STD CTR	1									0
					2708013 M1			E.B. BULL STD RH	1									0
					2708012 M1			E.B. BULL STD LH	1									0
K7 K8		6609000	372954281	2892141 M1			C.E. BULL STD										0	
		6609065	373954140	2969141 M1			C.E. BULL STD										0	
		6609013	372954279	2892139 M1			E.B. BULL STD										0	
		6609012	372954280	2892140 M1			E.B. BULL STD										0	
		6609038	397952304	2969329 M1			C.E. BULL STD										0	
		6609057	372954528	2968365 M1			C.E. BULL STD										0	
		6609048	372954497	2969056 M1			E.B. BULL STD										0	
		6609049	372954498	2969057 M1			E.B. BULL STD										0	
K10 K11		6609053		3074649 M1			C.E. BULL STD										0	
		6609054		3074650 M1			E.B. BULL STD									0		
		6609055		3074651 M1			E.B. BULL STD									0		
K12	ANGLE		395954129	2907254 M1	017-Q00-16	1	C.E. BULL STD CTR	2	180		1340		20	MT2	8	3/4"	36	
			395955240	2907533 M1	017-972-R97	4	E.B. BULL STD RH HC	1	183	212	335	365	25	MT2	5	3/4"	12	
			395955172		017-972-R97	4	E.B. BULL STD RH HC	1	183	212	335	365	25	MT2	5	3/4"	12	
			395955241	2907534 M1	017-972-L97	4	E.B. BULL STD LH HC	1	183	212	335	365	25	MT2	5	3/4"	12	
			395955173		017-972-L97	4	E.B. BULL STD LH HC	1	183	212	335	365	25	MT2	5	3/4"	12	
K12 D600C	ANGLE		395954129	2907254 M1	017-Q00-16	1	C.E. BULL STD CTR	2	180		1340		20	MT2	8	3/4"	36	
			395954205	2907326 M1	017-Q00-04	1	C.E. BULL STD CTR	2	180		1190		20	MT2	7	3/4"	32	
			396954126	2908810 M1	017-973-L96	4	E.B. BULL STD LH HC	1	171	203	350	410	25	MT2	6	3/4"	16	
			396954125	2908809 M1	017-973-R96	4	E.B. BULL STD RH HC	1	171	203	350	410	25	MT2	6	3/4"	16	
K12C K12D D600C	TILT		395955108	2907423 M1	017-Q00-04	1	C.E. BULL STD CTR	2	180		1190		20	MT2	7	3/4"	32	
			395955157	2907463 M1	017-Q00-05	1	C.E. BULL STD CTR	2	180		1450		20	MT2	8	3/4"	39	
			395955241	2907534 M1	017-972-L97	4	E.B. BULL STD LH HC	1	183	212	335	365	25	MT2	5	3/4"	12	
			395955240	2907533 M1	017-972-R97	4	E.B. BULL STD RH HC	1	183	212	335	365	25	MT2	5	3/4"	12	
K16 K16E		6609058	375955100	2900359 M1	017-Q00-03	1	C.E. BULL STD CTR	1	254		2522		25	MT2	17	3/4"	120	
		6609066	375954115	2900313 M1			C.E. BULL STD CTR	1									0	
		6609059	375955101	2900360 M1	104-909-L91	4	E.B. BULL STD LH HC	1	254	300	407	475	25	MT2	7	7/8"	24	
		6609060	375955102	2900361 M1	104-909-R91	4	E.B. BULL STD RH HC	1	254	300	407	475	25	MT2	7	7/8"	24	
		6609132	375955132	2900382 M1			C.E. BULL STD CTR	1									0	

Our parts are not original but they are interchangeable with them. The O.E.M. Part Numbers are give for reference purposes only.

# HANOMAG.MF-DOZERS

Cutting Edges and End Bits



**T O U G H  
C O M P O N E N T S**

Tractor Type	Blade Model	O.E.M. Part Number			MTM Number	Ref.	Description	No Pcs	Millimeters					Qty.	Nr. H.	Bolt Ø	W. Kg.	
		MILLER	HANOMAG	M. F.					W1	W2	L1	L2	T					
K18 D700C	ANGLE		311954119	2970059 M1			C.E. BULL STD CTR	1									0	
		6609060	375955102	2900361 M1	104-909-R91	4	E.B. BULL STD RH HC	1	254	300	407	475	25	MT2	7	7/8"	24	
		6609059	375955101	2900360 M1	104-909-L91	4	E.B. BULL STD LH HC	1	254	300	407	475	25	MT2	7	7/8"	24	
		6609060	375955102	2970058 M1			E.B. BULL STD RH	1									0	
		6609059	375955101	2970060 M1			E.B. BULL STD LH	1									0	
K18 D700C 710H16	TILT	6609058	375955100	2900359 M1	017-Q00-03	1	C.E. BULL STD CTR	1	254		2522		25	MT2	17	3/4"	120	
		6609060	375955102	2900361 M1	104-909-R91	4	E.B. BULL STD RH HC	1	254	300	407	475	25	MT2	7	7/8"	24	
		6609059	375955101	2900360 M1	104-909-L91	4	E.B. BULL STD LH HC	1	254	300	407	475	25	MT2	7	7/8"	24	
		6609060	375955102	2970058 M1			E.B. BULL STD RH	1									0	
		6609059	375955101	2970060 M1			E.B. BULL STD LH	1									0	
MF3366				2708008 M1			C.E. BULL STD CTR	1									0	
				982288 M2			E.B. BULL STD RH	1									0	
				982289 M2			E.B. BULL STD LH	1									0	
D400C				2719121 M1	017-Q00-01	1	C.E. BULL STD CTR	1	203		2337		19	MT2	15	5/8"	68	
				2708009 M1	104-907-L93	4	E.B. BULL STD LH HC	1	200	235	390	430	25	MT2	6	5/8"	17	
				2708010 M1	104-907-R93	4	E.B. BULL STD RH HC	1	200	235	390	430	25	MT2	6	5/8"	17	
				3113325 M1	017-Q00-15	1	C.E. BULL STD CTR	1	152		2282		19	MT2	15	5/8"	49	
				2817058 M1	017-Q00-02	1	C.E. BULL STD CTR	1	152		1881		19	MT2	12	5/8"	41	
				2708012 M1	104-908-L92	4	E.B. BULL STD LH HC	1	155	195	350	375	25	MT2	6	5/8"	13	
				2708013 M1	104-908-R92	4	E.B. BULL STD RH HC	1	155	195	350	375	25	MT2	6	5/8"	13	
MF400	ANGLE			2708008 M1			C.E. BULL STD CTR	1									0	
				2708009 M1	104-907-L93	4	E.B. BULL STD LH HC	1	200	235	390	430	25	MT2	6	5/8"	17	
				2708010 M1	104-907-R93	4	E.B. BULL STD RH HC	1	200	235	390	430	25	MT2	6	5/8"	17	
D400 D400C D400D	Moor			3094547 M1	017-Q00-13	1	C.E. BULL STD CTR	2	180		1054		20	MT2	6	5/8"	28	
				2902119 M1	017-971-L98	4	E.B. BULL STD LH HC	1	180	195	272	285	25	MT2	5	5/8"	12	
				2902118 M1	017-971-R98	4	E.B. BULL STD RH HC	1	180	195	272	285	25	MT2	5	5/8"	12	
D500E				2983745 M1	017-Q00-08	1	C.E. BULL STD CTR	2	180		1226		20	MT2	7	5/8"	33	
				2983746 M1	017-Q00-10	1	C.E. BULL STD CTR	2	180		1450		20	MT2	8	5/8"	39	
				2902119 M1	017-971-L98	4	E.B. BULL STD LH HC	1	180	195	272	285	25	MT2	5	5/8"	12	
				2902118 M1	017-971-R98	4	E.B. BULL STD RH HC	1	180	195	272	285	25	MT2	5	5/8"	12	
	Semi U				2983745 M1	017-Q00-08	1	C.E. BULL STD CTR	2	180		1226		20	MT2	7	5/8"	33
					2988184 M1			E.B. BULL STD	1									0
					2988185 M1			E.B. BULL STD	1									0
MF500				1088925 M1			C.E. BULL STD CTR	1									0	
				1088923 M1			E.B. BULL STD RH	1									0	
				1088924 M1			E.B. BULL STD LH	1									0	
				2707900 M1			C.E. BULL STD CTR	1									0	
				2707899 M1			E.B. BULL STD RH	1									0	
				2707898 M1			E.B. BULL STD LH	1									0	
				2708152 M1			C.E. BULL STD CTR	1									0	
				2708009 M1	104-907-L93	4	E.B. BULL STD LH HC	1	200	235	390	430	25	MT2	6	5/8"	17	
				2708010 M1	104-907-R93	4	E.B. BULL STD RH HC	1	200	235	390	430	25	MT2	6	5/8"	17	
D540E				2990021 M1			C.E. BULL STD CTR	2									0	
				2902088 M1	017-970-R99	4	E.B. BULL STD RH HC	1	180	198	335	380	25	MT2	5	5/8"	14	
				2902089 M1	017-970-L99	4	E.B. BULL STD LH HC	1	180	198	335	380	25	MT2	5	5/8"	14	
D600C				395954205	2907423 M1	017-Q00-04	1	C.E. BULL STD CTR	2	180		1190		20	MT2	7	3/4"	32
				395954129	2907251 M1	017-Q00-16	1	C.E. BULL STD CTR	2	180		1340		20	MT2	8	3/4"	36
				396954125	2908809 M1	017-973-R96	4	E.B. BULL STD RH HC	1	171	203	350	410	25	MT2	6	3/4"	16
				396954126	2908810 M1	017-973-L96	4	E.B. BULL STD LH HC	1	171	203	350	410	25	MT2	6	3/4"	16
				395955108	2907423 M1	017-Q00-04	1	C.E. BULL STD CTR	2	180		1190		20	MT2	7	3/4"	32
				395954311	2907505 M1	017-981-L94	4	E.B. BULL STD LH HC	1	181	235	355	375	25	MT2	6	3/4"	14
				395954310	2907504 M1	017-981-R94	4	E.B. BULL STD RH HC	1	181	235	355	375	25	MT2	6	3/4"	14

Our parts are not original but they are interchangeable with them. The O.E.M. Part Numbers are give for reference purposes only.

# HANOMAG.MF-DOZERS

Cutting Edges and End Bits



**T O U G H  
C O M P O N E N T S**

Tractor Type	Blade Model	O.E.M. Part Number			MTM Number	Ref.	Description	No Pcs	Millimeters					Qty.	Nr. H.	Bolt Ø	W. Kg.	
		MILLER	HANOMAG	M. F.					W1	W2	L1	L2	T					
D600D				2979214 M1	017-Q00-06	1	C.E. BULL STD CTR	2	180		1410		20	MT2	8	3/4"	38	
			395955241	2907534 M1	017-972-L97	4	E.B. BULL STD LH HC	1	183	212	335	365	25	MT2	5	3/4"	12	
			395955240	2907533 M1	017-972-R97	4	E.B. BULL STD RH HC	1	183	212	335	365	25	MT2	5	3/4"	12	
					3089416 M1	017-Q00-12	1	C.E. BULL STD CTR	2	180		1490		20	MT2	9	3/4"	40
				396954125	2908809 M1	017-973-R96	4	E.B. BULL STD RH HC	1	171	203	350	410	25	MT2	6	3/4"	16
				396954126	2908810 M1	017-973-L96	4	E.B. BULL STD LH HC	1	171	203	350	410	25	MT2	6	3/4"	16
					3086351 M1	017-Q00-11	1	C.E. BULL STD CTR	2	180		1260		20	MT2	7	3/4"	34
					3097592 M1	017-974-R95	4	E.B. BULL STD RH HC	1	180	200	365	420	25	MT2	5	3/4"	15
					3097593 M1	017-974-L95	4	E.B. BULL STD LH HC	1	180	200	365	420	25	MT2	5	3/4"	15
					2979795 M1	017-Q00-07	1	C.E. BULL STD CTR	2	180		117		20	MT2	7	3/4"	3
				395955241	2907534 M1	017-972-L97	4	E.B. BULL STD LH HC	1	183	212	335	365	25	MT2	5	3/4"	12
				395955240	2907533 M1	017-972-R97	4	E.B. BULL STD RH HC	1	183	212	335	365	25	MT2	5	3/4"	12
D700D				3095937 M1	017-Q00-14	1	C.E. BULL STD CTR	2	254		1325		25	MT2	9	7/8"	63	
				3095938 M1			E.B. BULL STD	1									0	
				3095939 M1			E.B. BULL STD	1									0	