

# MISCELLANEOUS

## Caterpillar Tamping Feet

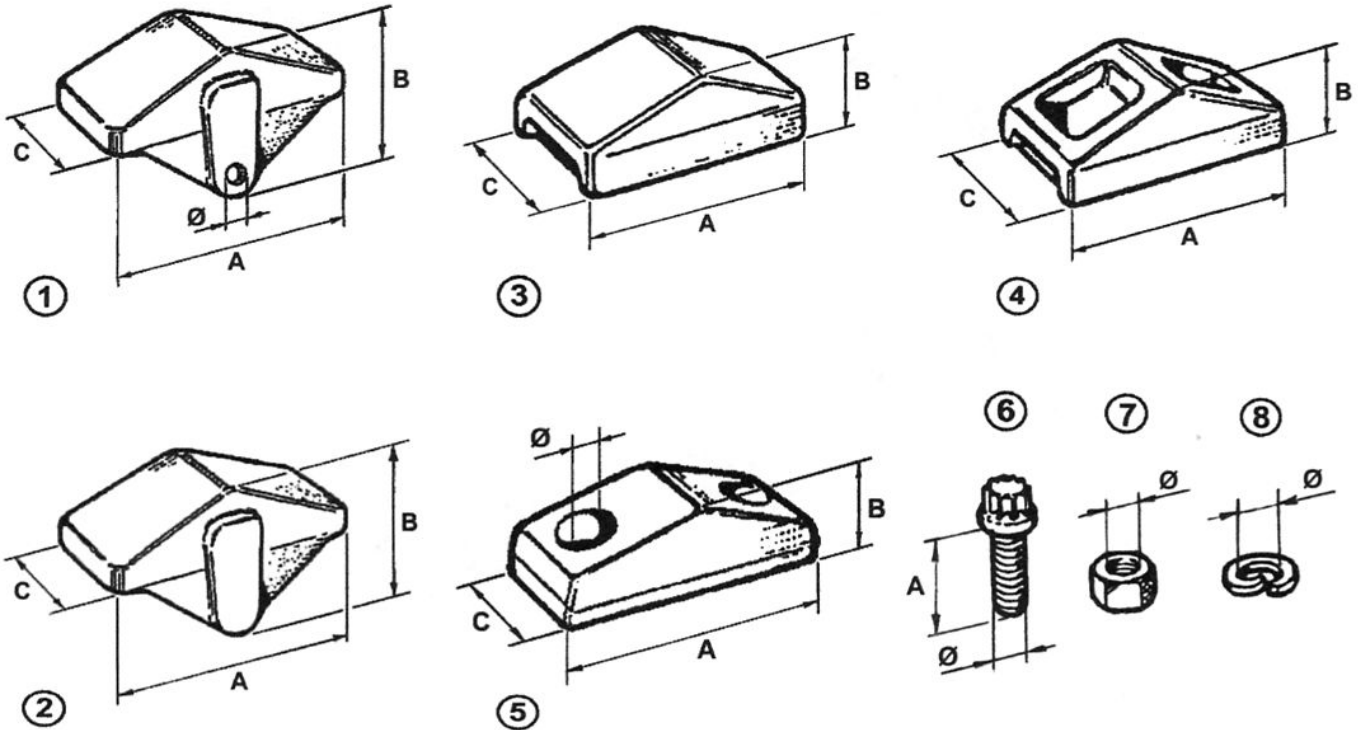

**T O U G H  
C O M P O N E N T S**



Model Machine	Tractor Type	O.E.M. Part N°	MTM Part N°	Description	Ref.	Millimeters				Weight Kg
						A	B	C	Ø	
835	44N1-332	7K 2939	01.199.X1M	Pinned T. Foot with holes	1	222	125	97	20	6,5
		7K 2939	01.199.X0M	Rock T. Foot no holes weld-on	2	222	125	97		6,5
	44N 333 UP	8K 9171	01.198.X1M	Tamp. Foot Bolt-on	5	230	83	76	23	6,5
		8K 9164	87.238.C00	Bolt	6	60			22	0,3
		7H 3609	87.D00.C60	Nut	7				22	0,1
		4D 6419	88.780.S00	Washer	8				23	0,0
834	43 E	7K 2939	01.199.X1M	Pinned T. Foot with holes	1	222	125	97	20	6,5
		7K 2939	01.199.X0M	Rock T. Foot no holes weld- on	2	222	125	97		6,5
825C	86X	2V 6628		Tamp. Foot weld-on						
		4V 0668	01.194.X1M	Rock T. Foot weld-on	3	222	90	84		6,9
		8K 9171	01.198.X1M	Tamp. Foot Bolt-on	5	230	83	76	23	6,5
		8K 9164	87.238.C00	Bolt	6	60			22	0,3
		7H 3609	87.D00.C60	Nut	7				22	0,1
		4D 6419	88.780.S00	Washer	8				23	0,0
825B/G	43 N	7K 2939	01.199.X1M	Pinned T. Foot with holes	1	222	125	97	20	6,5
824B	36G	7K 2939	01.199.X1M	Pinned T. Foot with holes	1	222	125	97	20	6,5
		7K 2939	01.199.X0M	Rock T. Foot no holes weld-on	2	222	125	97		6,5
815B	17Z	2V 7053	01.195.X1M	Tamp. Foot weld-on	4					4,0
815 815F	91P	8K 9189	01.197.X1M	Tamp. Foot Bolt-on	5	173	63	70	16	3,5
		4V 3851	01.196.X1M	Rock T. Foot no holes weld-on	3	169	71	79		4,3
		8K 9163	85.278.C00	Bolt	6	73			16	0,1
		7H 3607	85.D00.C60	Nut	7				16	0,1
		5S 0581	88.580.S00	Washer	8				16	0,1