

MISCELLANEOUS PACKING

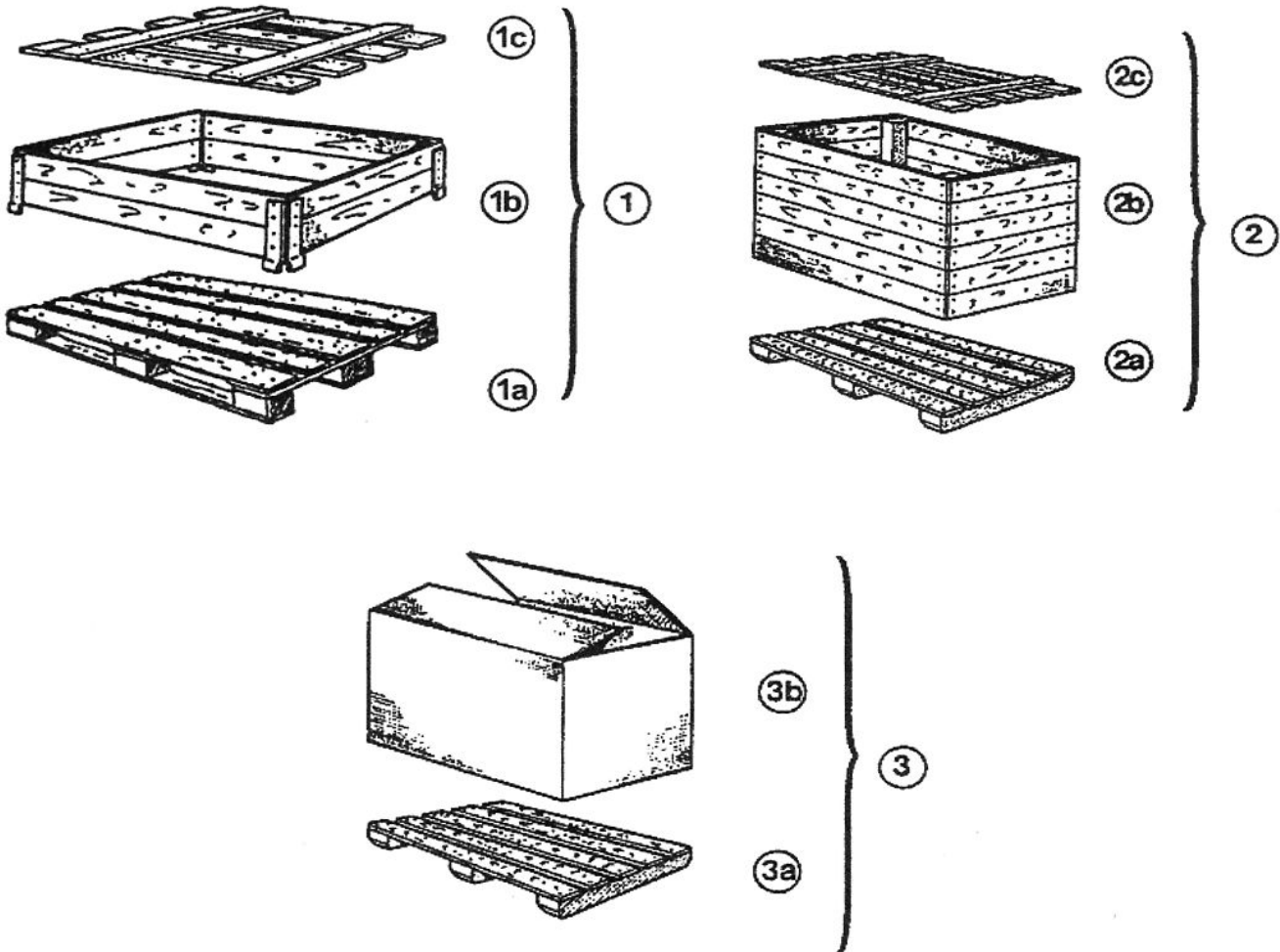

**T O U G H
C O M P O N E N T S**



MTM Part Nr.	Ref.	Description	Millimeters			Inches			Weight	
			Lenght	Width	Height	Lenght	Width	Height	Kg	Lbs
98.031.X3M	1a	Eur Pallet	1200	800	14	47,244	31,496	0,55	24	52,8
98.031.X2M	1b	Overlapping walls	1200	800	200	47,244	31,496	7,87	9,0	19,8
98.031.X1M	1c	Cover for case	1200	800	5	47,244	31,496	0,20	3,0	6,6
98.001.X0M	2	Sea Wooden case, compl.	105	83	71	4,13	3,27	2,80	44	96,8
98.001.X3M	2a	Pallet	105	83	12	4,13	3,27	0,47	12	26,4
98.001.X2M	2b	Walls for case	105	83	55	4,13	3,27	2,17	30	66
98.001.X1M	2c	Cover for case	105	83	5	4,13	3,27	0,20	2,0	4,4
98.023.X0M	3	Carton Case, small, compl.	62	40	54	2,44	1,57	2,13	13	28,6
98.023.X3M	3a	Pallet	62	40	12	2,44	1,57	0,47	5,0	11
98.023.X2M	3b	Cover for case	62	40	42	2,44	1,57	1,65	8,0	17,6